

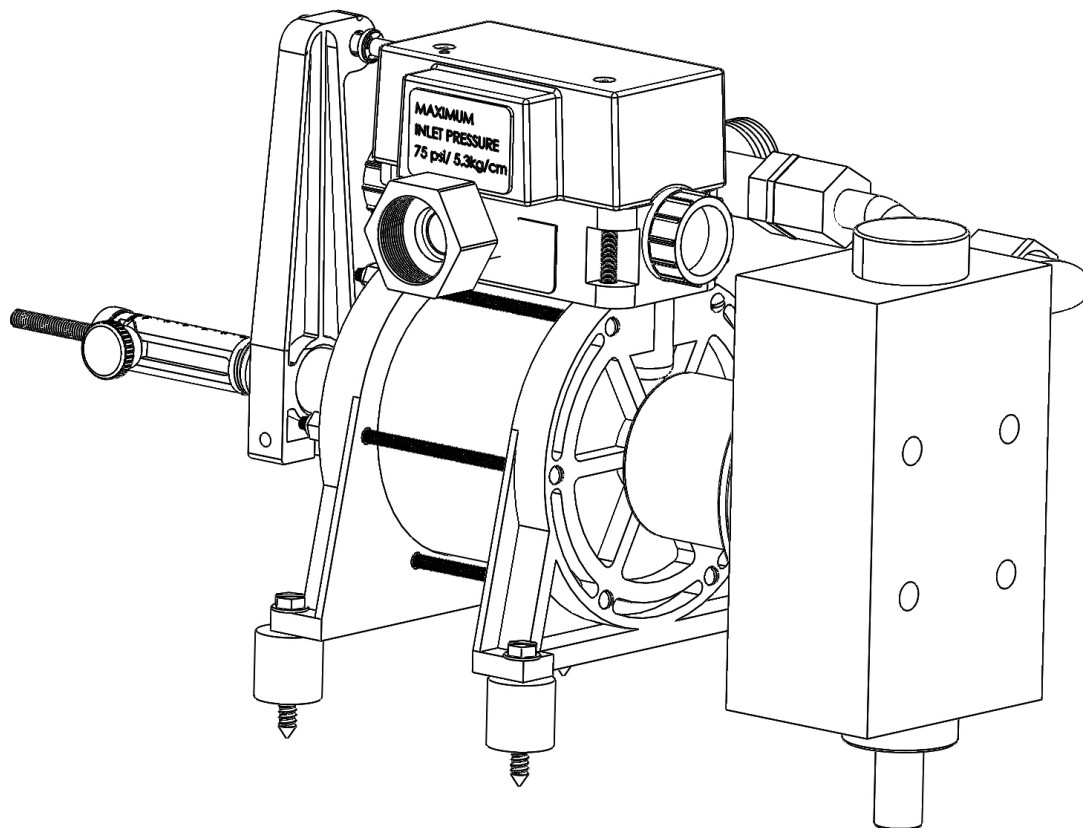

Operating Manual

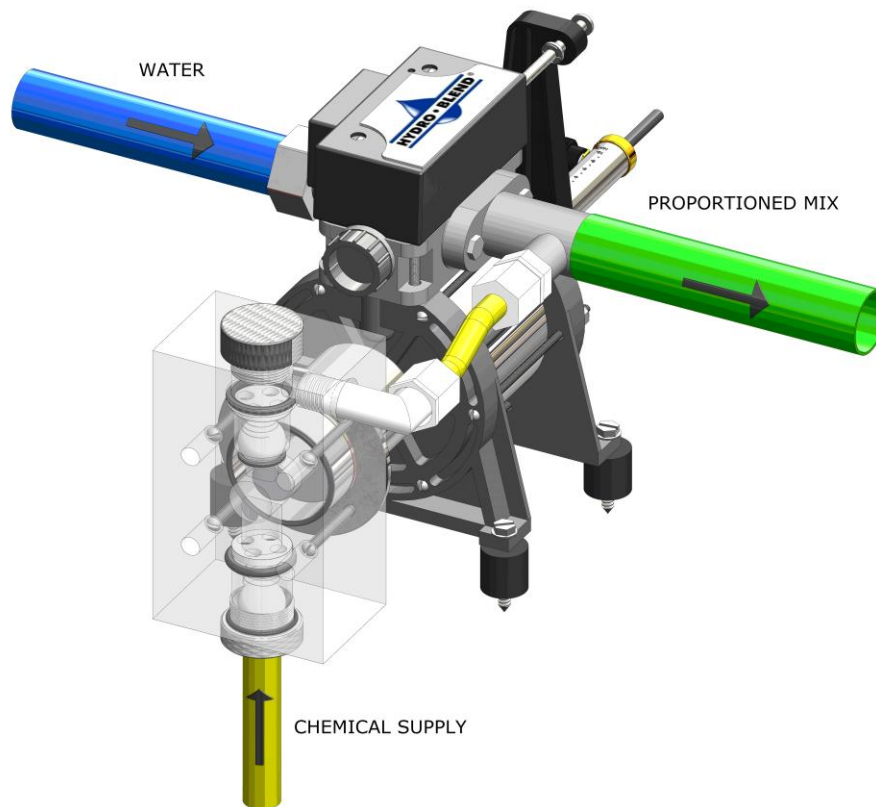



INSTALLATION

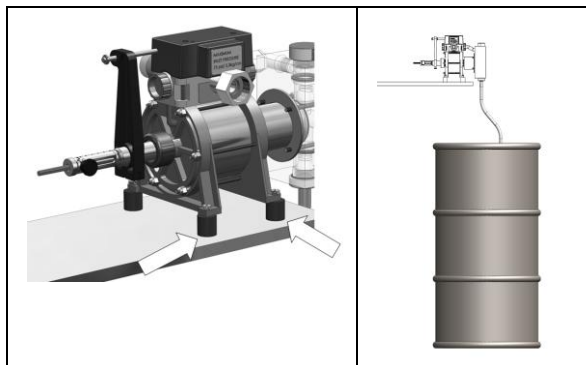

1. Mount the proportioner on a bracket or shelf using the (4) rubber feet provided. See attached pages for horizontal or vertical mounting instructions

NOTE: MOUNT THE UNIT SO THE BOTTOM OF THE BRACKET IS 42" FROM THE FLOOR. THIS WILL ALLOW A DRUM OF PRODUCT TO BE PLACED UNDER THE PROPORTIONER.

2. Install a 25 micron water filter in the inlet water line of the proportioner. Failure to filter the proportioner water supply will void warranty. If the inlet water pressure can exceed 75 PSI, a regulator should be installed in the inlet water line.

NOTE: THE PROPORTIONER IS DESIGNED TO BE USED WITH 3/4" GARDEN HOSE CONNECTIONS FOR BOTH THE WATER INLET AND OUTLET. THE UNIT CAN BE CONNECTED WITH RIGID PIPE IF DESIRED. ALL NECESSARY HOSES AND PIPING MUST BE SUPPLIED.

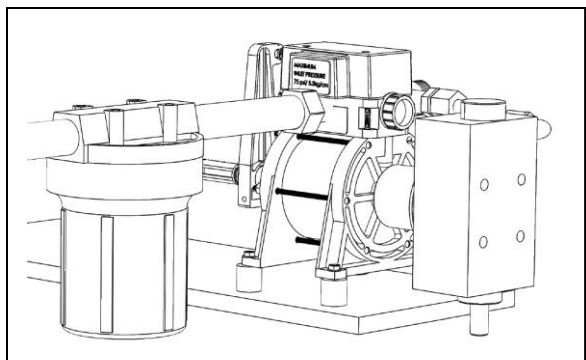

PART # 9256 WATER FILTER ASSEMBLY

3. On the discharge side of the proportioner, connect the pipe or line which will feed the mixture to a central reservoir or to the mixture use points. If you are using pipe to make these connections, use a 3/4" Garden Hose to NPT adapter.
4. Attach the suction tube to the chemical pump and place the bottom end of the tube into the product container.

INSTALLATION DIAGRAMS

The Hydroblend Proportioner is water powered and can therefore be located near an isolated water source without electrical connections. Installation is simple, straightforward and takes very little time.

Below are some simple installation setups:

Basic Installation:

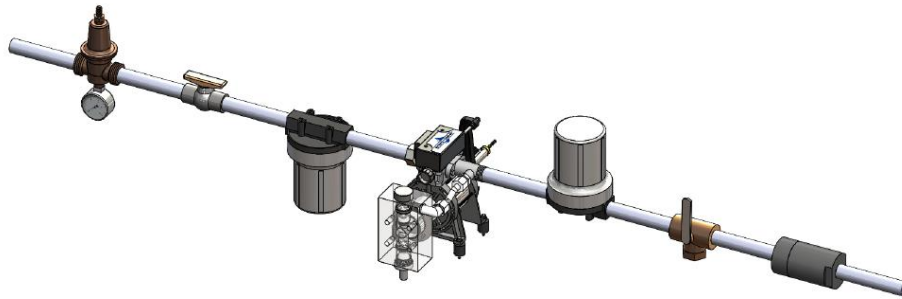

By-Pass Installation:

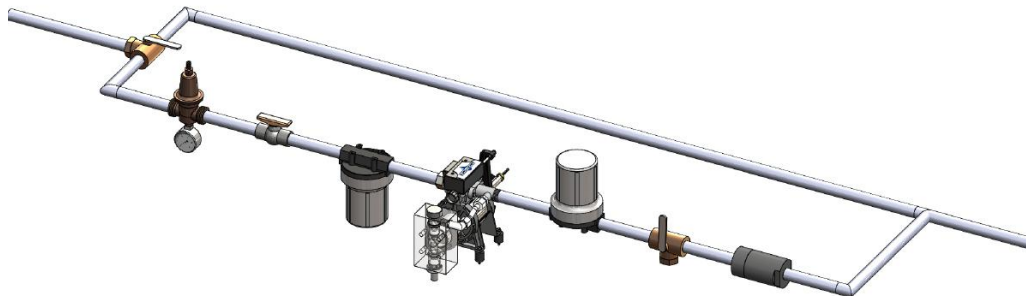

Parallel Installation:

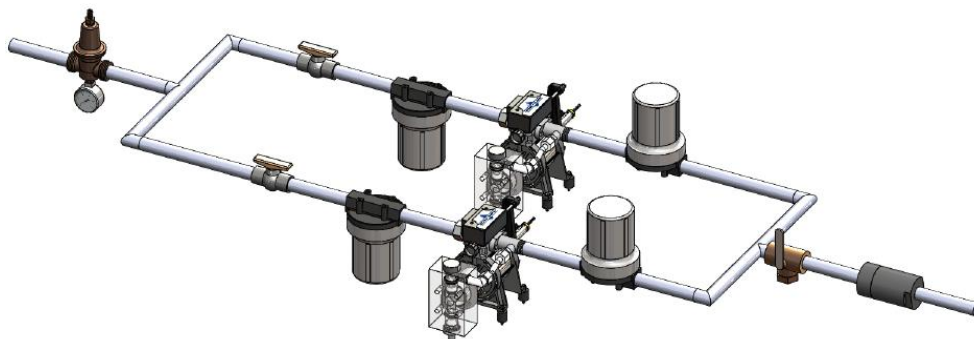

MACHINE START-UP

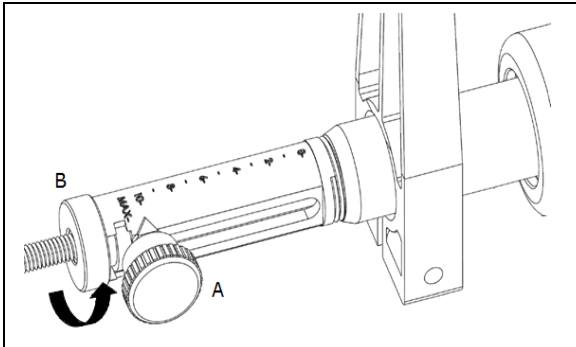

1. If your proportioner is a variable ratio model, loosen the adjustment locking knob (A) and turn the concentration adjustment knob (B) to the maximum setting (Position 10)
2. If your proportioner is a fixed water to chemical ratio model (no concentrate adjustment mechanism), disregard step 1 (note picture #2).
3. Check all connections and fittings for proper tightness and turn on the water to the machine.

NOTE: THE PLASTIC FITTINGS ON THE PROPORTIONER ONLY NEED TO BE TIGHTENED BY HAND FOR PROPER SEALING.

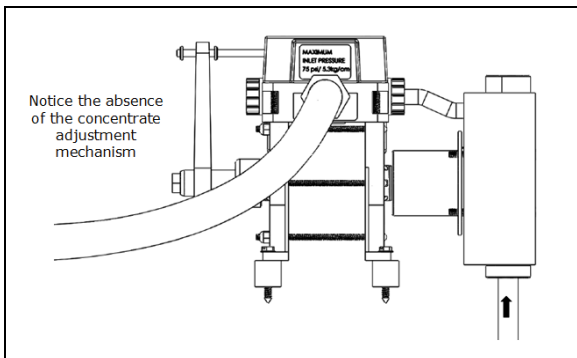

4. As water flows through the water motor of the proportioner, the actuating arm and piston at the rear of the proportioner will move back and forth. This shaft operates the chemical pump piston. The concentrate will start rising up the suction tube.

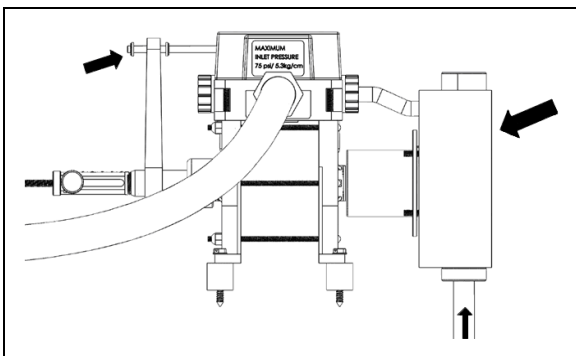

5. Once the product leaving the chemical pump reaches the main water stream, a 3-5 gallon sample can be taken of the mixture for a concentration test (either titration, volumetrically, or with a refractometer). If a variable ratio unit, you may adjust the concentration knob as needed to give the desired product-to-water ratio. The numbers on the graduated guide are reference marks only, and do not represent any particular ratio. The #10 is the strongest concentration and the #0 is the weakest. When the proper ratio is reached, tighten the adjustment locking knob. Finger tight is sufficient.

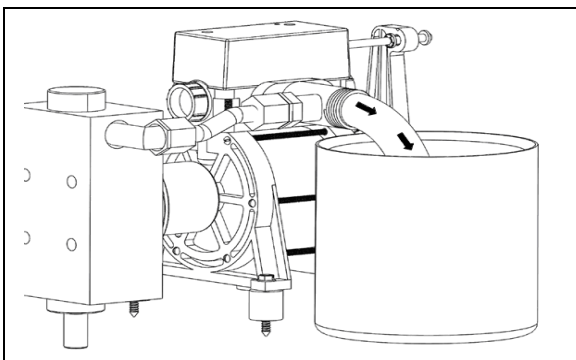

The proportioner must be installed in compliance with all local plumbing codes. The proportioner water feed line must be isolated because chemical back flow through the proportioner is possible. An approved back flow preventer must be installed upstream from the proportioner to prevent possible chemical contamination of the water supply.

TROUBLESHOOTING

Issues

Causes

Corrections

1. Water motor will not run

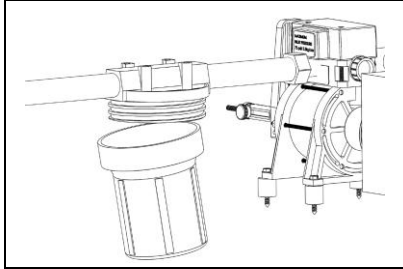

- A. Water turned off to unit.
- B. Water filter clogged.
- C. Discharge lines shut off or clogged
- D. Proportioner stalled. Proportioner operates intermittently, and then stalls.

- A. Turn water on to unit.
- B. Remove and replace filter element.
- C. Check to be sure lines are clear and all system valves are open.
- D. Water inlet pressure has dropped. Relieve downstream back pressure. If unit restarts, there is no problem. If unit does not restart, the valve block may need to be rebuilt.

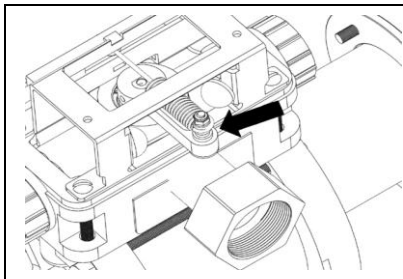

- E. Weak or broken toggle lever spring
- F. Actuating Arm out of adjustment

- E. Replace toggle lever spring.
- F. Relocate actuating arm to .400" from back of chrome shaft. See attached print.

2. Will not draw chemical

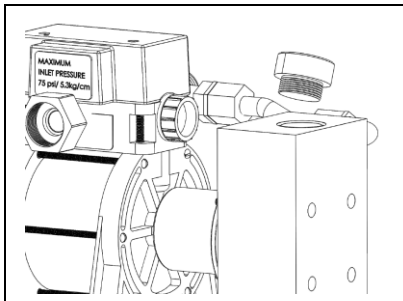

- A. Water motor not working.
- B. Proportioner concentrate adjustment set on minimum.
- C. Pump head seals dry.
- D. Upper or lower valve screws sucking air.
- E. Foreign material on ball seat. Concentrate has caused balls to stick.

- A. Check motor per item 1 above
- B. Re-adjust. Set on 10 to prime.
- C. Remove top valve screw, flood cavity with water. Replace spring and valve screw carefully. Start unit.
- D. Tighten fittings - hand tight only.
- E. Remove valve balls carefully and clean. Flush and clean ball o'rings in place carefully. Replace balls, springs and upper and lower valve screws carefully.

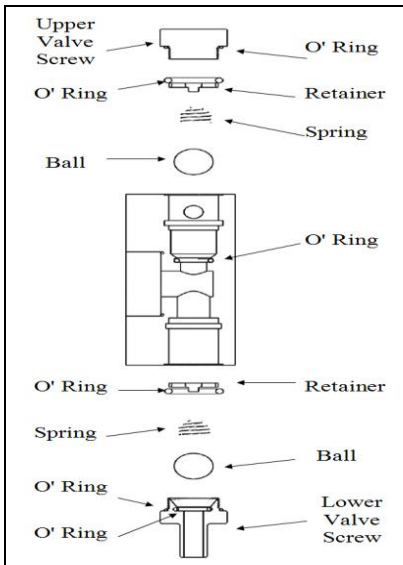

- F. Excessive discharge backpressure.

- F. Relieve downstream back pressure until unit is primed.



INSTALLATION ADDENDUM

LEAKING-DRIZZLING FLOAT VALVES

Occasionally non-positive water flow valve can be encountered in older, somewhat dated, press recirculating system. This is the least desirable installation, however, the Hydroblend will operate accurately and repeatedly in this environment.

After the system is filled at full flow and if the level is maintained with a leaky-never fully on, never fully off float valve, the Hydroblend may have to be reset at slightly higher settings to maintain the desired dilution.

Although the Hydroblend operates at water flows much lower than any other device of its type, a small amount of water will bypass the upper valve block. As the total flow decreases to a trickle, that bypass will represent a greater percentage of the total flow volume thus the mixture may be slightly more dilute. This will require a slightly richer chemical setting. Correspondingly, at this setting and at full flow, the mixture may be a little rich.

The best solution would be to eventually install a positive on-off flow valve.

Please call our Customer Service department with any further questions.

HYDROBLEND INTERNATIONAL CORPORATION

5301 Sawyer Ave * Boise, Idaho 83714 * USA * Ph (208) 375-5000, Fax (208) 378-9963 * Email sales@hydroblend.com
www.hydroblend.com US Pat. # 4,279,229 * US Pat. # 5,433,240 * US Pat. # 6,485,272 B2

NOTE: HYDRO-BLEND HORIZONTAL PUMP PART NUMBERS CONTAIN THE ABBREVIATION "HM"
 THIS ABBREVIATION DENOTES THE PUMPS MOUNTING ORIENTATION (SEE PACKING SLIP FOR PUMP PART NUMBER)

HM = HORIZONTAL MOUNT - DESIGNED TO MOUNT ON A HORIZONTAL SURFACE (I.E. A SHELF)

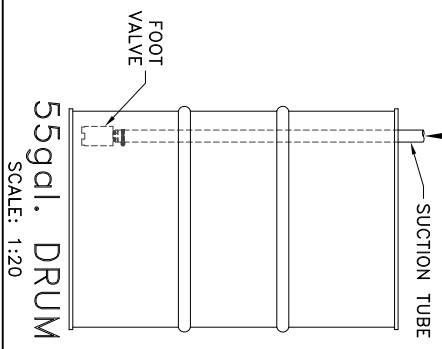
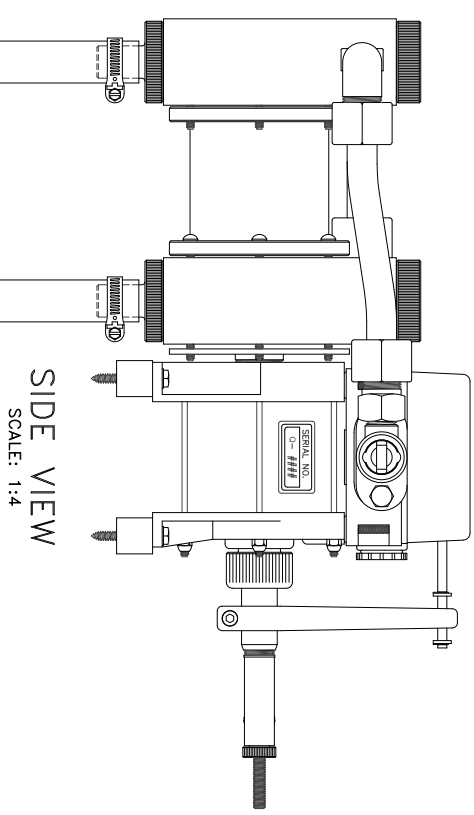
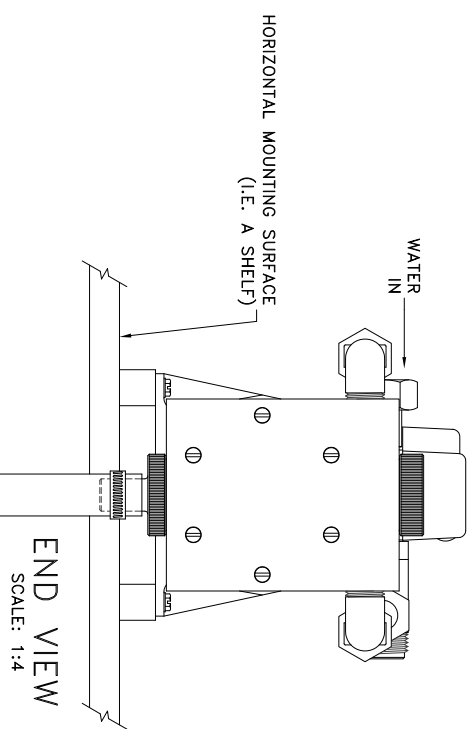

SCALE:		SHEET:		DATE:	
NOTED		1 of 1		02/05/07	
DRAWN BY:		CHECKED BY:		DATE:	
SC		DK		01/16/14	
SERIES:		DESCRIPTION:		PART NUMBER:	
SC		MOUNTING INSTRUCTIONS		MV6540 HORIZONTAL MOUNT	
REGION:		REVISED BY:		DATE:	
SC		SC		01/16/14	

C:\AUTOCAD\GROWM\Paper-Mounting-Instructions\8550-HM-Mounting-Instructions.dwg

HYDRO-BLEND

5301 SAWYER AVENUE BOISE, ID 83714
 PHONE: (208) 375-5000 www.hydroblend.com

NOTE: HYDRO-BLEND VERTICAL MOUNT PUMP PART NUMBERS CONTAIN THE ABBREVIATION "VM"
 THIS ABBREVIATION DENOTES THE PUMPS MOUNTING ORIENTATION (SEE PACKING SLIP FOR PUMP NUMBER)

VM = VERTICAL MOUNT - DESIGNED TO MOUNT ON A VERTICAL SURFACE (I.E. A WALL)

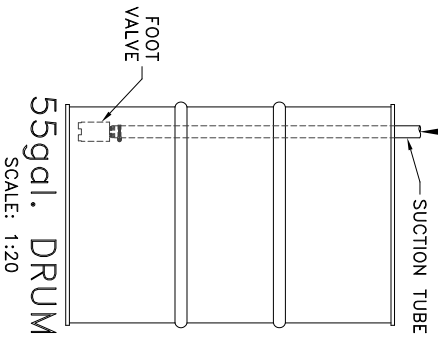
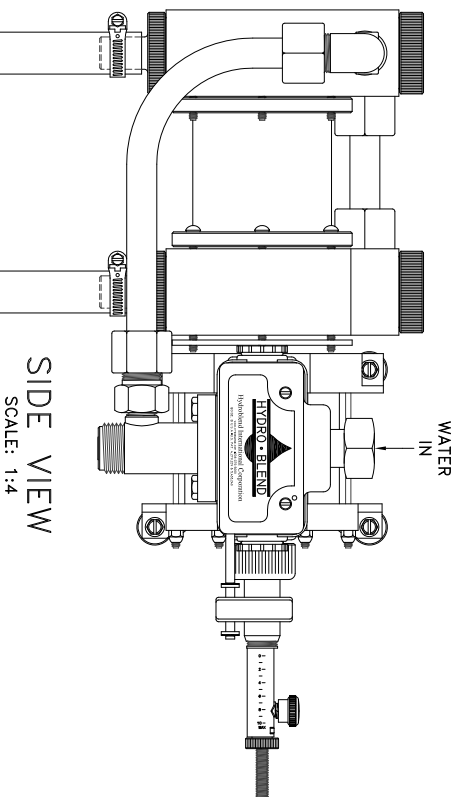
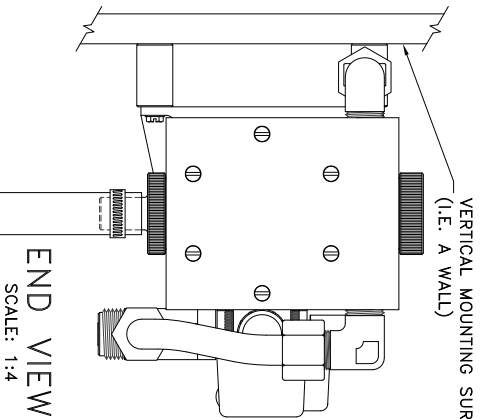

SCALE:		SHEET:		DATE:	
NOTED		1 of 1		02/05/07	
DRAWN BY:		CHECKED BY:		DATE:	
SC		DK		01/16/14	
SERIES:		DESCRIPTION:		PART NUMBER:	
SC		MOUNTING INSTRUCTIONS		MV6540 VERTICAL MOUNT	
REVISION:		REMOVED BY:		DATE:	
		SC			

C:\AUTOCAD\9300VM\Paper-Work\Mounting-Instructions\8850-VM-Mounting-Instructions.dwg



HYDRO-BLEND
 Mechanical Equipment Corporation
 5301 SAWYER AVENUE BOISE, ID 83714
 PHONE: (208) 375-5000 www.hydroblend.com

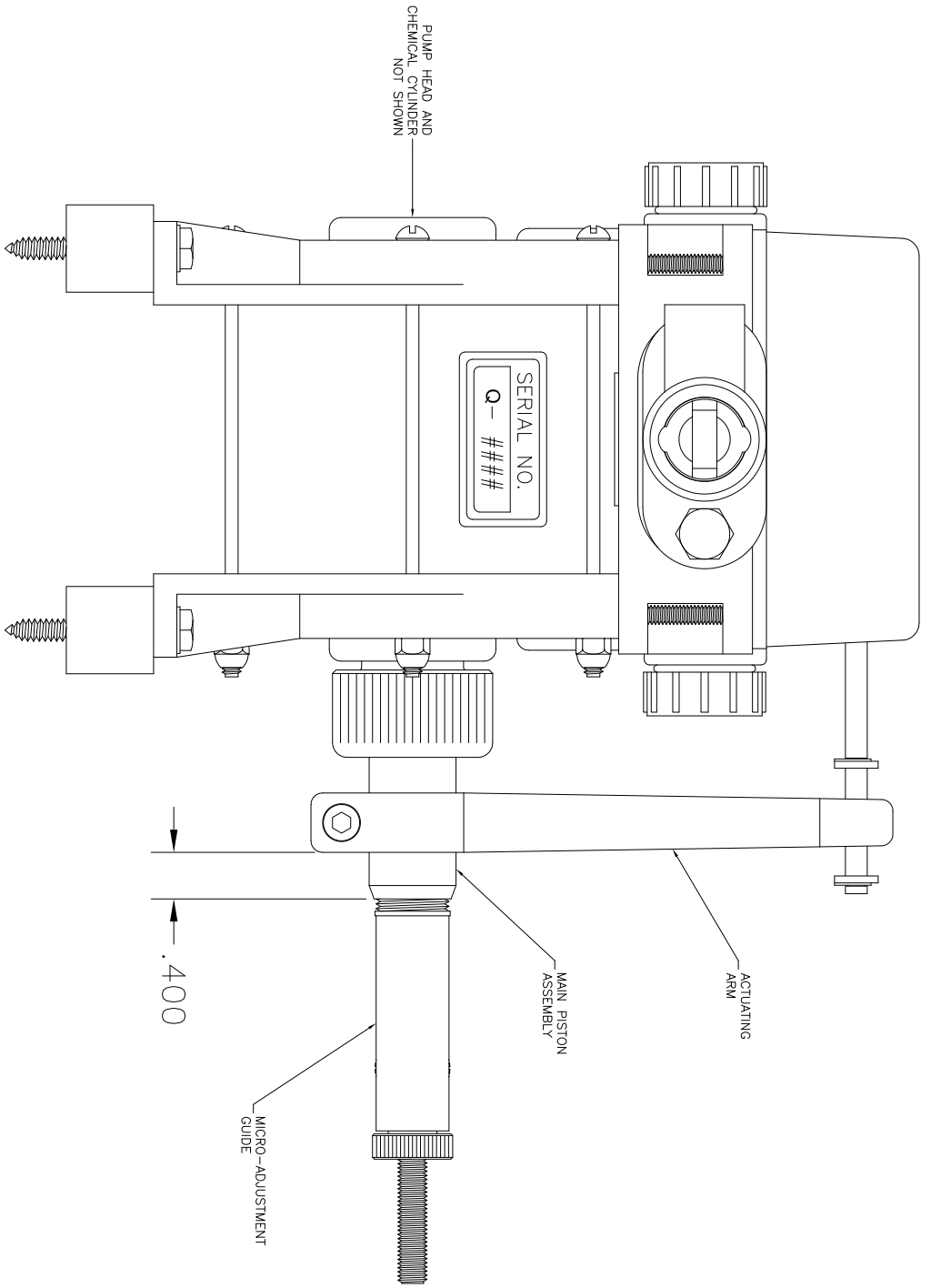

SCALE:	1:1.5	SHEET:	1 of 1	DATE:	02/07/07
DRAWN BY:	SC	CHECKED BY:	DK		
SERIES:		DESCRIPTION:			
REVISION:		REvised BY:	SC	DATE:	07/14/08

C:\AUTOCAD\GROWM\Figures\www\Operating Manual\Actuating Arm Adjustment.dwg

HYDRO-BLEND

5301 SAWYER AVENUE BOISE, ID 83714
 PHONE: (208) 375-5000 www.hydroblend.com

ACTUATING ARM
ADJUSTMENT



LIMITED EXPRESS WARRANTY

WARRANTY

Hydroblend International Corporation hereinafter "Hydroblend", warrants to the original purchaser that Hydroblend equipment will be free from defects in materials and/or workmanship under normal use and service for a period of 12 months from the date of sale (invoice date). Hydroblend's liability shall, at its option, be limited to repair or replacement of the defective equipment.

CONDITIONS AND EXCEPTIONS

- A) Hydroblend shall be responsible only for parts and labor costs incurred by Hydroblend and its personnel. Purchaser shall be responsible for all other repair and/or replacement costs including but not limited to freight and travel costs incurred by non-Hydroblend personnel.
- B) The warranty does not apply to any damage or loss to any equipment or components resulting from alteration or modification by unauthorized persons, fire, accident, acts of god, misuse or abuse, or failure to install or operate the equipment in strict compliance with the operating instructions, or any other cause whatsoever other than defects in workmanship and/or materials.
- C) This warranty specifically excludes damages resulting from a chemical incompatibility with the materials of construction or operating the units a water temperature in excess of 135F. The suitability of a particular material of construction is the sole responsibility of the purchaser.
- D) The listed capabilities of an individual unit are based on products with a SSU of 31 at 70F, having a specific gravity of water. A decrease in ambient temperature may result in a corresponding increase in viscosity and a loss of metering capacity. Specific gravity and viscosity related metering reduction are outside the scope of this limited express warranty and are specifically excluded therefrom.

PURCHASER'S OBLIGATION

All equipment is sold FOB Hydroblend's factory and all responsibility for, and risk of, loss or damage in transit is borne by purchaser. Any claims, loss or damage resulting from shipment must be settled between purchaser and purchaser's freight carrier.

LIMITATION OF LIABILITY

HYDROBLEND SHALL NOT BE LIABLE FOR SPECIAL, INDIRECT OR CONSEQUENTIAL DAMAGES.

Hydroblend shall not be liable from loss of any income or profits due to the malfunctioning of any equipment covered under the Warranty, whether the malfunctioning is caused by defects in workmanship and/or materials, or for any cause whatsoever. The remedies of purchaser set forth herein are exclusive, and the liability of Hydroblend with respect to any contract or sale or anything done in connection therewith, whether in contract, in tort under any warranty, or otherwise shall not exceed the price of the equipment or parts on which such liability is based.

MERGER

THE WARRANTY DESCRIBED IN THE ABOVE PARAGRAPHS SHALL BE IN LIEU OF ANY OTHER WARRANTIES, EXPRESS, OR IMPLIED, INCLUDING BUT NOT LIMITED TO, ANY IMPLIED WARRANTY OR MERCHANTABILITY OR FITNESS FOR A PARTICULAR PURPOSE. HYDROBLEND NEITHER ASSUMES NOR AUTHORIZES ANY PERSON TO ASSUME FOR IT, ANY OTHER LIABILITY IN CONNECTION WITH THE SALE OR USE OF THE EQUIPEMNT SOLD HEREUNDER, AND THERE ARE NO ORAL AGREEMENTS OR WARRANTIES COLLATERAL TO, OR AFFECTING THIS AGREEMENT.

HYDROBLEND INTERNATIONAL CORPORATION

5301 Sawyer Ave * Boise, Idaho 83714 * USA * Ph (208) 375-5000, Fax (208) 378-9963 * Email sales@hydroblend.com
www.hydroblend.com US Pat. # 4,279,229 * US Pat. # 5,433,240 * US Pat. # 6,485,272 B2